

**IEIP** 金沙星座·科创园

**文化建设设计方案** CULTURAL CONSTRUCTION  
DESIGN SCHEME

正俯视图



国际创客港展示方案



- LOGO**
- 1、足1.2mm厚304不锈钢激光切割四周折边100mm,无缝焊接打磨;
  - 2、面层:5mm亚克力雕刻造型UV打印画面;
  - 3、背板:20mm全结皮PVC封底;
  - 4、主龙骨60镀锌方管焊接;
  - 5、不锈钢表面刮灰打磨,喷氟碳漆饰面(底漆面漆均三遍);
  - 6、内置光源(蓝鲸LED光源,内部满铺);
  - 7、高空安装、制作、运输;

- 文字**
- 1、足1.2mm厚304不锈钢冲孔字激光切割四周折边100mm,无缝焊接打磨;
  - 2、背板:20mm全结皮PVC固定安装;
  - 3、主龙骨60镀锌方管焊接;
  - 4、不锈钢表面刮灰打磨,喷氟碳漆饰面(底漆面漆均三遍);
  - 5、内置光源(蓝鲸LED光源,字表面满铺);
  - 6、高空安装、制作、运输;

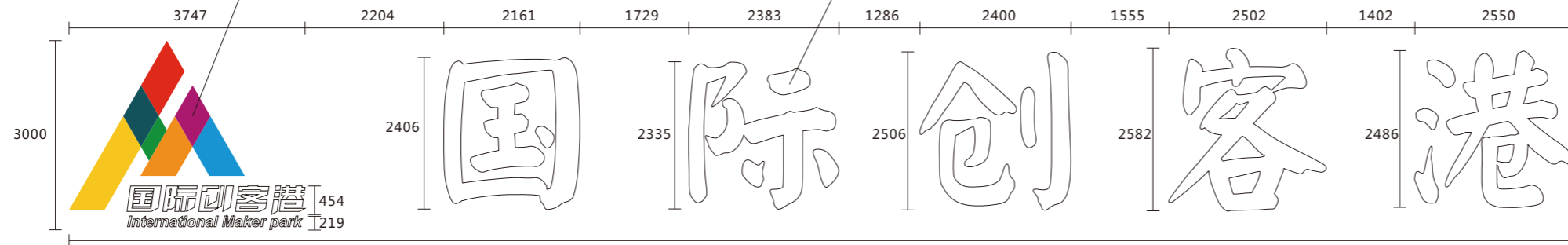

立面图

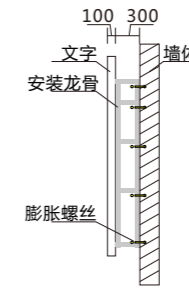

侧面图

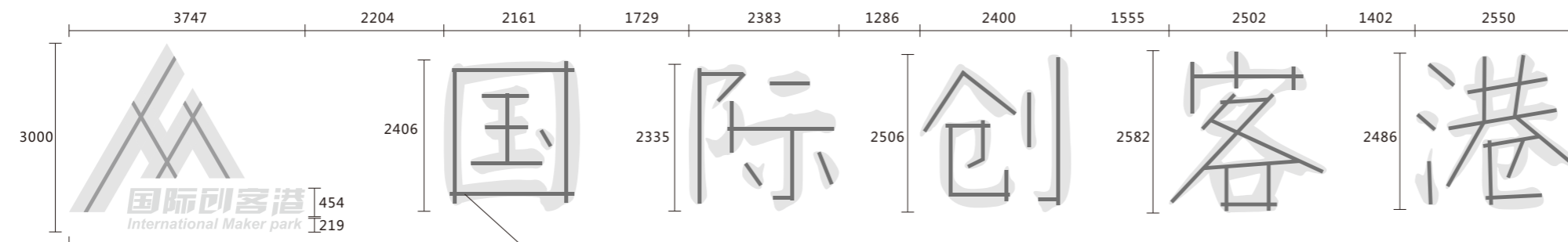

字体龙骨立面图

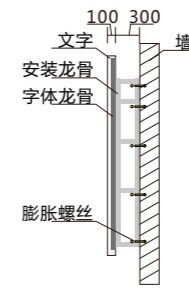

侧面图

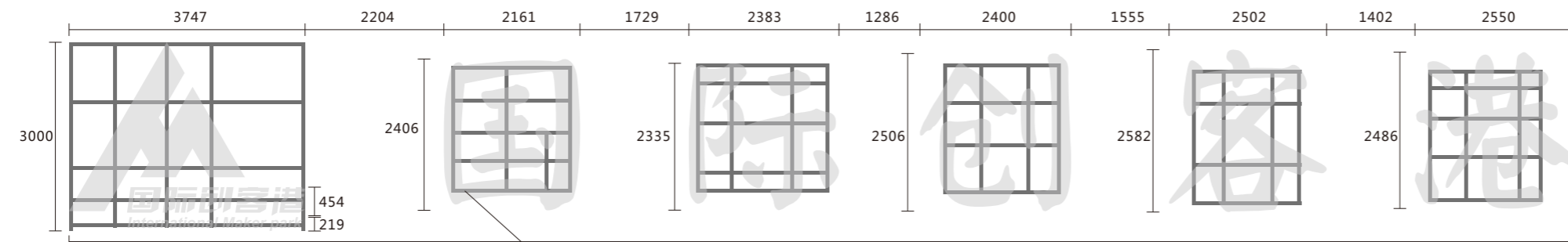

安装龙骨立面图

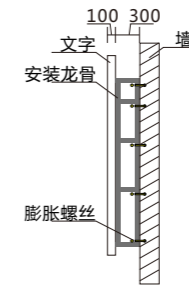

侧面图

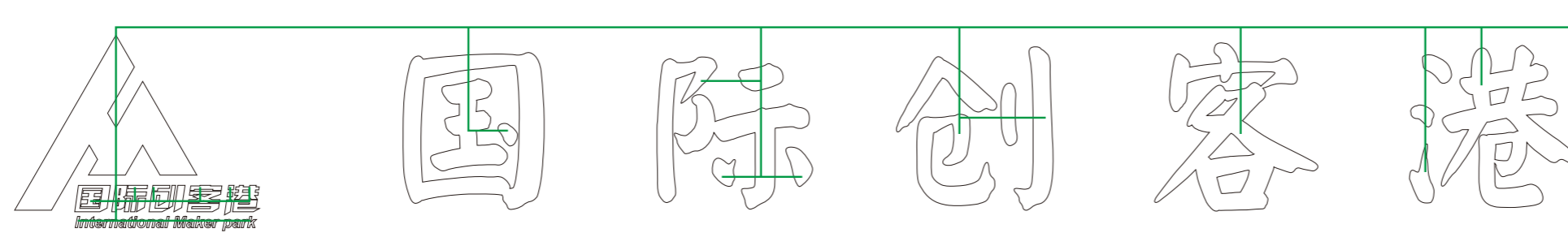

电路图

渝奥集团展示方案



- LOGO :**
- 1、足1.2mm厚304不锈钢激光切割四周折边100mm,无缝焊接,打磨;
  - 2、面层:5mm亚克力雕刻造型UV打印画面;
  - 3、背板:20mm全结皮PVC封底;
  - 4、主龙骨60镀锌方管焊接;
  - 5、不锈钢表面刮灰打磨,喷氟碳漆饰面(底漆面漆均三遍);
  - 6、内置光源(蓝鲸LED光源,内部满铺);
  - 7、高空安装、制作、运输;

- 文字 :**
- 1、足1.2mm厚304不锈钢冲孔字激光切割,四周折边100mm,无缝焊接,打磨;
  - 2、背板:20mm全结皮PVC固定安装;
  - 3、主龙骨60镀锌方管焊接;
  - 4、不锈钢表面刮灰打磨,喷氟碳漆饰面(底漆面漆均三遍);
  - 5、内置光源(蓝鲸LED光源,字表面满铺);
  - 8、高空安装、制作、运输;

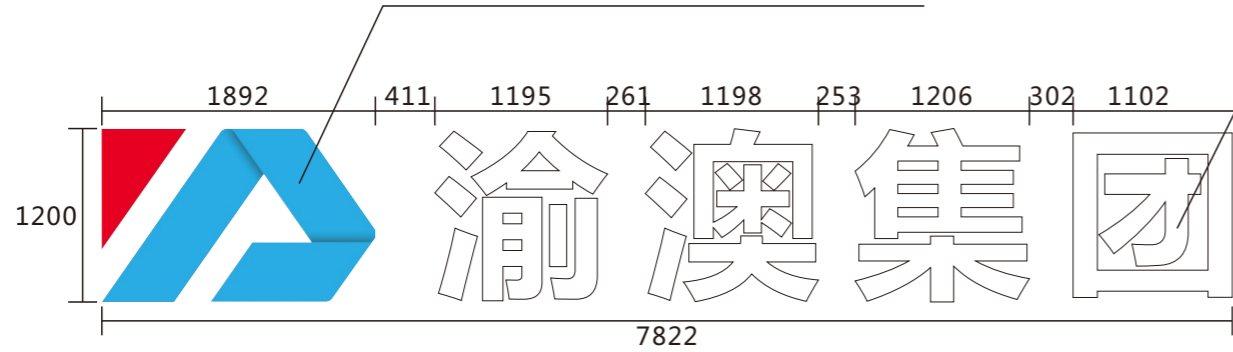

立面图

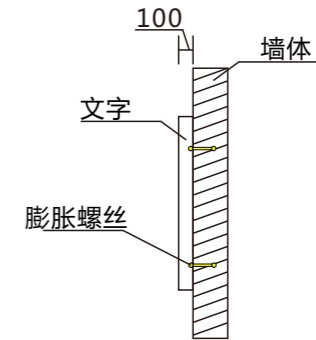

侧面图

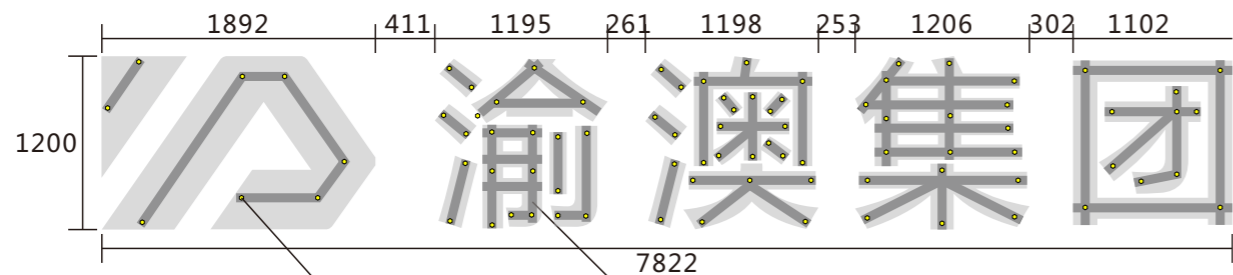

膨胀螺丝 安装龙骨60镀锌方管焊接、防锈漆处理;

字体龙骨立面图

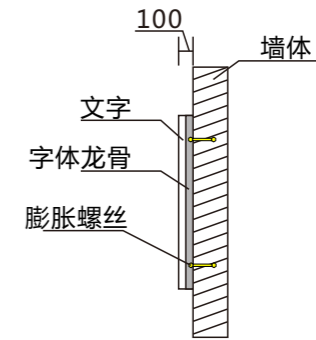

侧面图

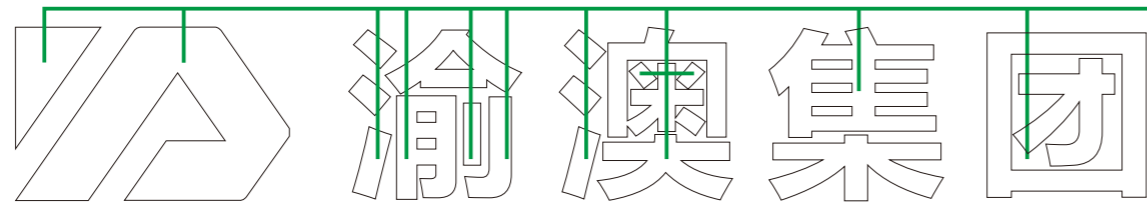

电路图

C65N-C32/2P ZRBV-3x6 PVC20-AC/WC  
 电线引至原配电箱内约200m  
 国标箱体(根据现场尺寸制作),本次设计采用配电箱1个  
 配时控开关

利美华胤巨幕影城展示方案

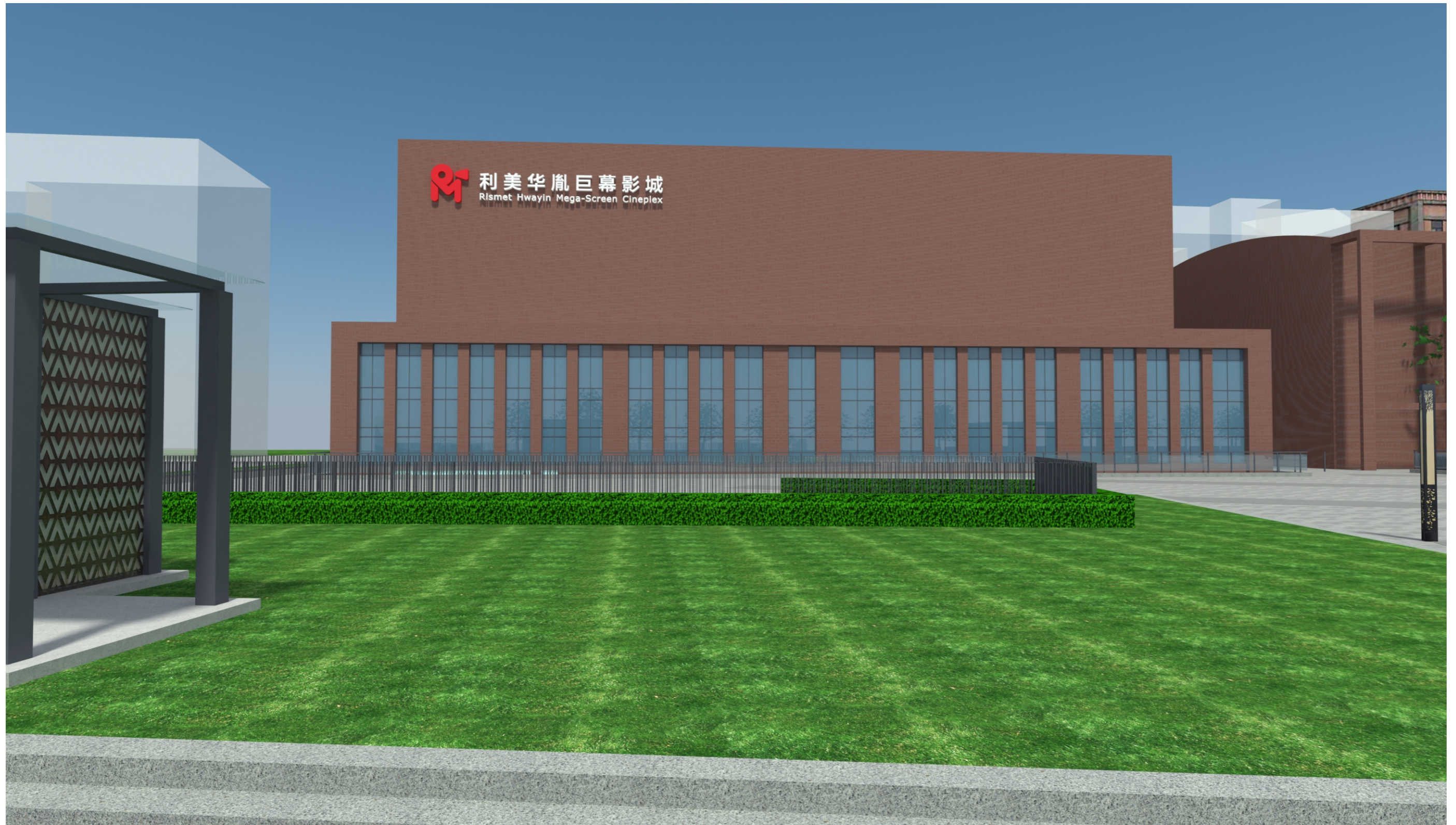

- LOGO :**
- 1、足1.2mm厚304不锈钢激光切割四周折边100mm,无缝焊接,打磨;
  - 2、面层:5mm亚克力雕刻造型UV打印画面;
  - 3、背板:20mm全结皮PVC封底;
  - 4、主龙骨60镀锌方管焊接;
  - 5、不锈钢表面刮灰打磨,喷氟碳漆饰面(底漆面漆均三遍);
  - 6、内置光源(蓝鲸LED光源,内部满铺);
  - 7、高空安装、制作、运输;

- 文字 :**
- 1、足1.2mm厚304不锈钢冲孔字激光切割,四周折边100mm,无缝焊接,打磨;
  - 2、背板:20mm全结皮PVC固定安装;
  - 3、主龙骨60镀锌方管焊接;
  - 4、不锈钢表面刮灰打磨,喷氟碳漆饰面(底漆面漆均三遍);
  - 5、内置光源(蓝鲸LED光源,字表面满铺);
  - 6、高空安装、制作、运输;

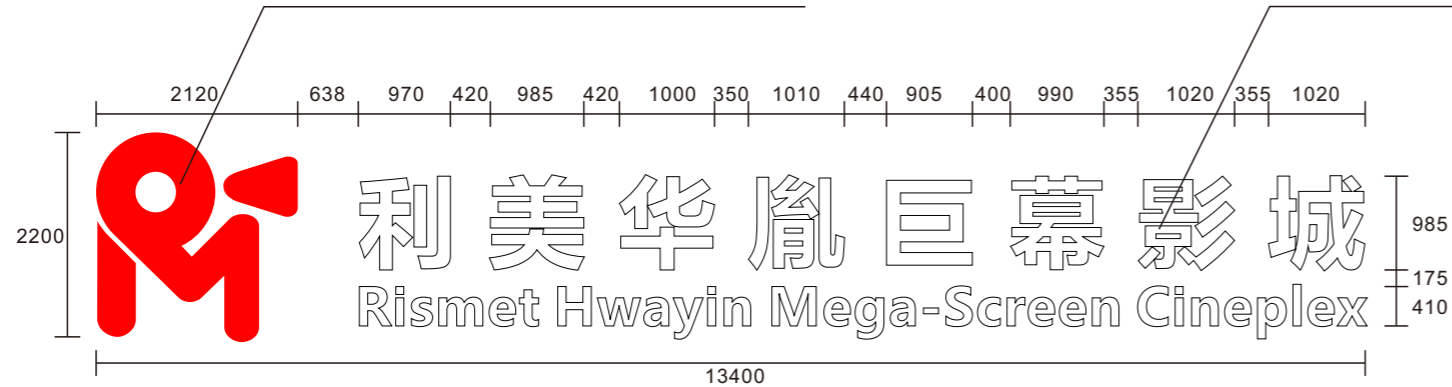

立面图

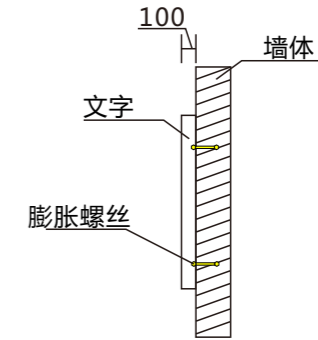

侧面图

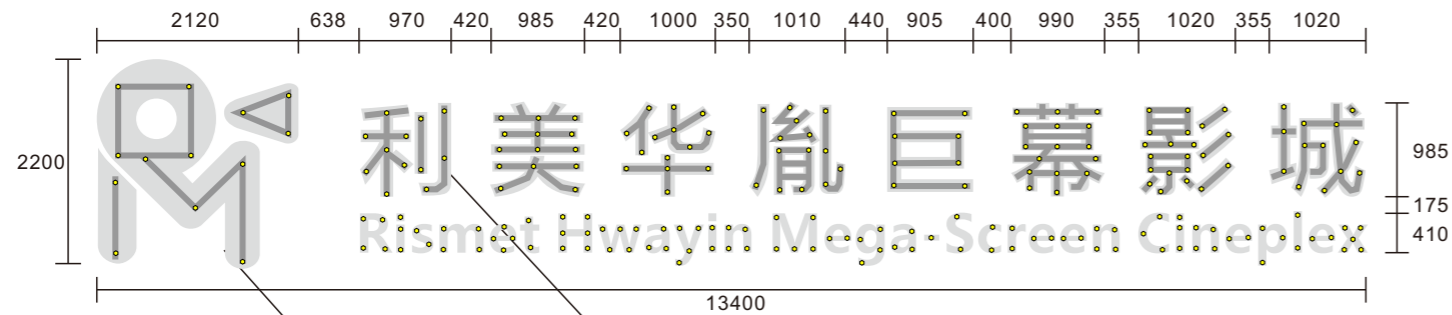

膨胀螺丝

字体龙骨60镀锌方管焊接、防锈漆处理;

字体龙骨立面图

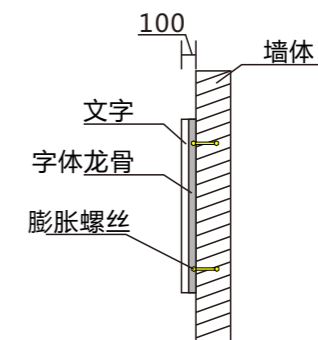

侧面图



C65N-C32/2P ZRBV-3x6 PVC20-AC/WC

电线引至原配电箱内约200m

国标箱体(根据现场尺寸制作),本次设计采用配电箱1个  
配时控开关

电路图